



► Product Description

Silicon carbide is a synthetically produced, high-hardness material based on silicon and carbon. It is available in black and green variants and is used as an abrasive and functional material in industrial applications.

The following data refer to black silicon carbide (SiC black). Different specifications apply to green silicon carbide. Further information is available upon request.

► Technical Properties

Mohs hardness:	9.6
Melting point:	Approx 2300 °C
Density:	Approx 3.2 g/cm ³

► Chemical Composition (average analysis)

Grain size	SiC	free C	Fe ₂ O ₃
F012–F090	≥98.5 %	≤0.2 %	≤0.2 %
F100–F180	≥98.0 %	≤0.3 %	≤0.3 %
F220	≥97.5 %	≤0.3–0.6 %	≤0.3–0.6 %
F240–F320	≥98.5 %	≤0.18 %	≤0.19 %
F400–F1200	≥98.0 %	≤0.20 %	≤0.20 %

► Grain Sizes and Classification

Available according to FEPA standard:

- ▷ **Macro grits:** F010 – F220
- ▷ **Micro grits:** F230 – F1200

Custom grain size distributions available on request.

► Typical Applications

- ▷ Grinding and blasting media
- ▷ Lapping and polishing applications
- ▷ Additive for refractory materials
- ▷ Component of anti-slip surfaces
- ▷ Aggregate for industrial flooring
- ▷ Green SiC additionally: semiconductor applications



► Performance Characteristics

- ▶ very high hardness
- ▶ defined grain size distribution
- ▶ suitable for abrasive applications
- ▶ suitable for use at elevated temperatures

► Packaging and Delivery

- ▶ 25 kg paper sacks
Shipping up to 50 kg per package
From 75 kg on pallet with shrink hood
- ▶ 0.5 – 1.5 t PP big bags (ISO 21898)
with or without inliner
on pallet with shrink hood.
- ▶ Each batch is labelled with:
product name, batch number, quantity, and production date.

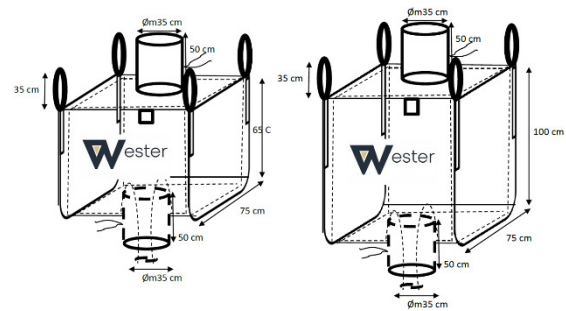

► Storage

For optimal product quality:

- ▶ protect from moisture
- ▶ avoid excessive sun exposure
- ▶ store at moderate temperatures
- ▶ reseal opened containers
- ▶ store on stable surfaces

► Note

The above information reflects our current experience. Users are responsible for verifying suitability for their specific application. Liability is governed by contractual agreements unless otherwise specified by law.

► Contact

If you have any questions regarding shelf life and storage, please feel free to contact us – we will be happy to advise you at any time. The selection of the appropriate grain size and specification depends on the application and process parameters; technical support is also available upon request.